

# TANDEM waste/recycle set with SERVO-DRIVE

## Application



## Description

- Pre-assembled bottom mount set
- TANDEM plus BLUMOTION heavy duty full extension concealed drawer runners
- For 15", 18" and 21" wide cabinets with 12", 15" and 18" minimum opening widths
- For 16 (5/8") max. drawer side thickness
- For face frame and panel applications
- Tool-free height and tilt adjustment
- Maximum 6 (1/4") cabinet bottom recess
- 125 lb static, 110 lb dynamic load rating
- SERVO-DRIVE touch-to-open feature

## Basic components

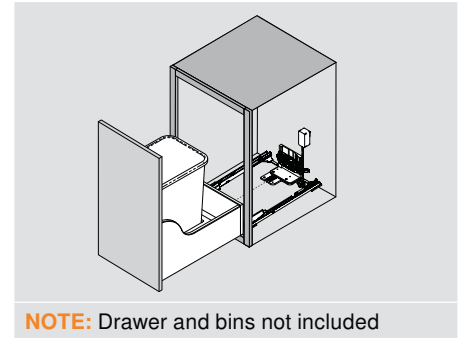

**NOTE:** Drawer and bins not included

## Components

### TANDEM waste/recycle set

**SERVO-DRIVE**  
inside

**BLUMOTION**  
inside

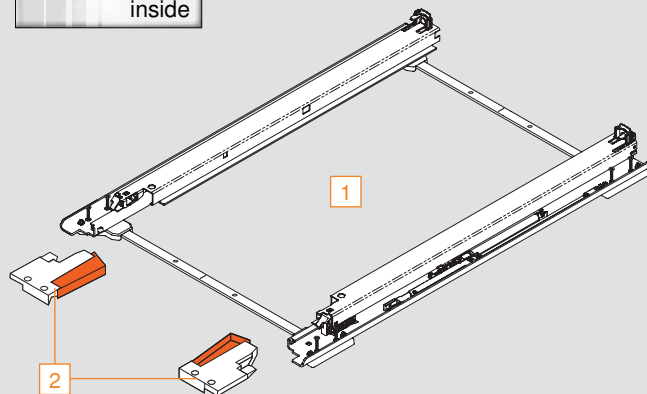

#### Set includes:

- 1 TANDEM plus BLUMOTION heavy duty runner set with pre-mounted #6 x 1" wood screws for installation (qty 8)
  - 2 Standard locking device (qty 2) with #6 x 1/2" truss head wood screws for installation (qty 4)
- Installation template and instructions

TANDEM waste/recycle set	Drawer length	Part no.
For 12" min. opening width	533 (21")	568R5337BB
For 15" min. opening width	533 (21")	568R5337BD
For 18" min. opening width	533 (21")	568R5337BF

### SERVO-DRIVE waste/recycle set

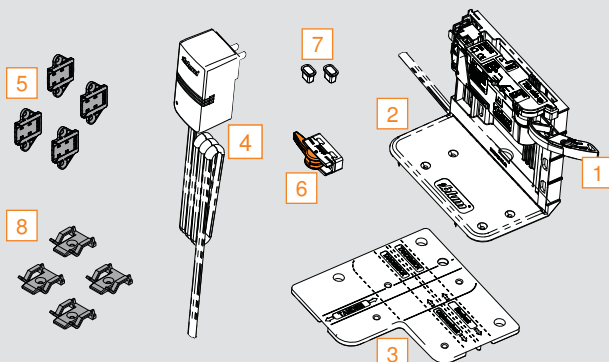

#### Set includes:

- 1 Drive unit (pre-attached)
  - 2 Double bottom bracket with #6 x 1" wood screws (qty 2)
  - 3 Adapter plate
  - 4 110V plug-in power supply with six feet of universal cable
  - 5 Screw-on distance bumpers (qty 4) with #6 x 5/8" wood screws for installation (qty 8)
  - 6 INSERTA cable connector
  - 7 Cable end protectors (qty 2)
  - 8 Cable clips (qty 4)
- Installation template, instructions and user manual

Part no.

SERVO-DRIVE waste/recycle set	Z10NA20UGUS
-------------------------------	-------------

**NOTE:** Power supply will operate up to two drive units in a double bottom bracket application (second drive unit sold separately)

# Specifications

**SERVO-DRIVE**  
inside

**BLUMOTION**  
inside

## Drawer and cabinet specifications

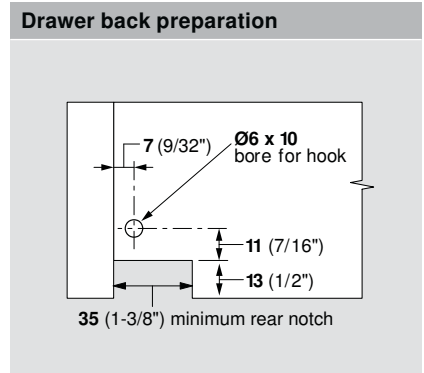
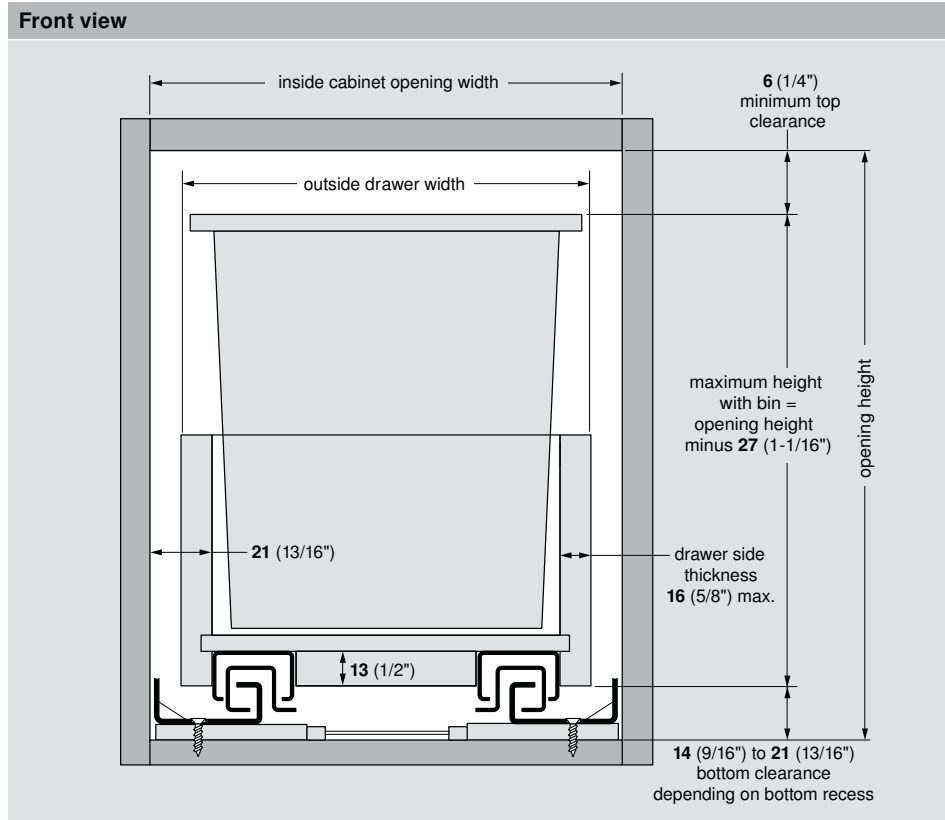

**i Important**

Bin width and height must be considered when designing your cabinet and drawer (see diagram to the left).

Minimum inside cabinet depth

With SERVO-DRIVE	577 (22-11/16")
Without SERVO-DRIVE	556 (21-7/8")

Waste/recycle set	Min. inside cabinet opening width	For drawer side thickness				
		16 (5/8")	15 (19/32")	14 (9/16")	13 (1/2")	12 (15/32")
568R5337BB	305 (12")	295 (11-5/8")	293 (11-17/32")	291 (11-7/16")	289 (11-3/8")	287 (11-9/32")
568R5337BD	381 (15")	371 (14-5/8")	369 (14-17/32")	367 (14-7/16")	365 (14-3/8")	363 (14-9/32")
568R5337BF	457 (18")	447 (17-5/8")	445 (17-17/32")	443 (17-7/16")	441 (17-3/8")	439 (17-9/32")

**NOTE:** Drawer length is 533 (21") for all sets

Outside drawer width

**Installation**

Place drawer on runners and close. Locking devices automatically connect to runners.

**Removal**

- Squeeze orange release levers on locking devices
- Pull drawer out and up

**Height adjustment**

- Press up on adjustment tab
- Push toward back of drawer

Maximum 3 (1/8") rise of drawer front

**Tilt adjustment**

Rotate the tilt adjustment lever on the rear of each runner to tilt the top of the drawer front forward. This allows a tool-free tilt adjustment of +5 (3/16").

**NOTE:** Detailed drawings of recommended drawer box specifications are available at [blum.com](http://blum.com)